

DREXELBROOK  
Engineering Company

# RF Level and Flow Controls

---

---

## Installation and Operating Instructions

---

---

for

**Drexelbrook Z-tron™ Level Control  
502-3000 Series**

**with a 402-2000 Transmitter**

*For factory service, call toll-free :  
1-800-527-6297*

TM: Trademark of Drexelbrook Eng. Co.

Copyright 1992  
Drexelbrook Engr. Co.  
Printed in U.S.A.



**Installation and Operating Instructions**  
**for**  
**Drexelbrook Z-tron™ Level Control**  
**502-3000 Series**  
**with a 402-2000 Transmitter**

*For factory service, call toll-free :*  
**1-800-527-6297**

TM: Trademark of Drexelbrook Eng. Co.

Copyright 1992  
Drexelbrook Engr. Co.  
Printed in U.S.A.



# Table of Contents

SECTION	PAGE
1.0 Introduction .....	1
1.1 System Description .....	2
1.2 Model Numbers .....	2
2.0 Specifications .....	3
3.0 Installation .....	4
3.1 Unpacking .....	4
3.2 Mounting .....	4
3.3 Sensing Element Wiring .....	5
3.4 Power Wiring .....	5
3.5 Relay Connections .....	6
4.0 Operation/Calibration .....	8
4.1 Start-Up .....	8
4.2 Controls .....	8
4.3 Calibration Procedures .....	9
4.4 Blind Method of Calibration .....	11
4.5 Calibration of Time-Delay Units .....	11
4.6 Recalibration .....	11
5.0 Troubleshooting .....	12
5.1 Introduction .....	12
5.2 Testing the Electronics .....	12
5.3 Testing the Sensing Element .....	14
5.4 Testing the Spark Protection .....	15
5.5 Testing the Relay Circuits .....	16
5.6 Possible Problems and Causes .....	17
6.0 Factory & Field Service .....	18
6.1 Telephone Assistance .....	18
6.2 Equipment Return .....	18
6.3 Field Service .....	18
6.4 Customer Training .....	19



## 1.0 Introduction

This manual describes the Drexelbrook Z-tron™ Level Switch Series 502-3000 with a 402-2000 transmitter.

### 1.1 System Description

The Z-tron Series control includes a sensing element with integral electronics as shown in Figure 1-1.

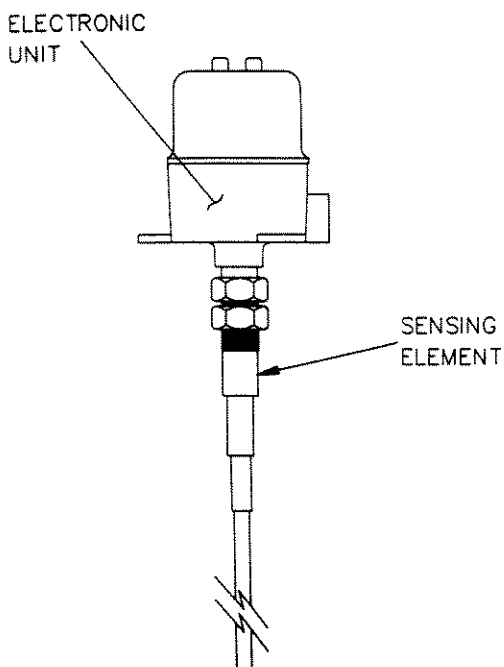

Figure 1-1  
Z-tron Series Level Control

The Drexelbrook Z-tron control is a precision RF (radio frequency) relay output level switch. It provides relay contact closure when material reaches a preset point in a vessel. The standard double-pole double-throw relay contacts may be used to operate alarms, solenoid valves, or other low power devices.

Cote-Shield™ action is designed into each unit and enables the instrument to ignore the effects of most build-up or material coatings on the sensing element, when properly installed and applied.

The Z-tron control is mounted so that the sensing element is in or near the material being measured. It provides a change in RF admittance indicating presence or absence of material. The sensor portion consists of three sections; center (measuring portion), ground, and Cote-Shield. The Cote-Shield terminal guards against the transmission of RF current through most coatings on the sensing element (from the center measuring element to ground) until the level reaches the setpoint. See Figure 1-2.

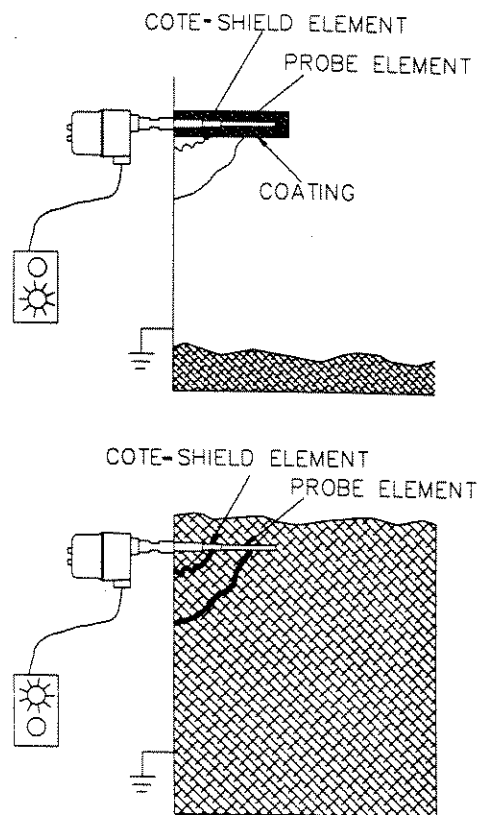

Figure 1-2  
Cote-Shield Terminal

# **Introduction**

## **1.2 Model Numbers**

502-3000 (Z-tron)	Standard 115 Vac
502-3002 (Z-tron T/D)	Standard 115 Vac with 0-90 second time delay.
502-3200 (Z-tron D)	24 Vdc
502-3300 (Z-tron F)	115/230 Vac
502-3020 (Z-tron B)	115 /Vac with high sensitivity electronics (for light granulars, 3 to 25 lbs./cu. ft.)
502-3022 (Z-Tron B/TD)	115 Vac with high sensitivity electronics with 0-90 second time delay.



## 2.0 Specifications

- A. Power Requirement:**  
 Z-tron and Z-tron TD,  
 Z-tron B and Z-tron B/TD: 95-145  
 Vac, 3 watts  
 Z-tron D: 24 ( ± 3) Vdc, 3 watts  
 Z-tron F: 115/230 ( ± 15) Vac, 3  
 watts
- B. Sensitivity:** .3pF or less for Z-tron  
 .02pF for Z-tron B
- C. Fail-Safe:** Field adjustable to  
 either High-Level Fail-Safe (HLFS)  
 or Low-Level Fail-Safe (LLFS)
- D. Load Resistance:**  
 Center to Ground, 1500Ω  
 Center to Shield, 750Ω  
 Shield to Ground, 750Ω
- E. Output:** DPDT Relay Closure
- F. Ambient Temperature:** -40°F to  
 145°F (The units will operate  
 above 145°F but with reduced  
 component life.)
- G. Line Voltage Effect:** Z-tron is  
 .2pF/20V @ 120 Vac. Z-tron B is  
 .002pF/20V @ 120 Vac.
- H. Temperature Effect:** .Z-tron is  
 3pF/50°F. Z-tron B is .01pF/40°F.
- I. Contact Rating:** Non-inductive 5A  
 @ 117 Vac or 2.5A @ 230 Vac
- J. Stability:** .1pF/6 mo. max. shift for  
 Z-tron. .01pF/6 mo. max. shift for  
 Z-tron/B.
- K. Housing:**The standard explosion-  
 proof housing meets the follow-  
 ing classifications:
- |      |    |                   |
|------|----|-------------------|
| Nema | 1  | General-Purpose   |
| Nema | 2  | Drip-Tight        |
| Nema | 3  | Weather-Resistant |
| Nema | 4  | Waterproof        |
| Nema | 5  | Dust-Tight        |
| Nema | 12 | Industrial Use    |
- L. Sensing Element:**  
 Operating Temperature: 40°F to  
 250°F  
 200 psi pressure.  
 316 ss wetted metal parts.
- M. Spark Tolerance:** 10 amp  
 standard. 100 amp optional.

### 3.0 Installation

#### 3.1 Unpacking

Carefully remove the contents of the shipping carton and check each item against the packing list before destroying any packing materials. If there is any shortage or damage, report it immediately to the factory.

#### 3.2 Mounting

The Z-tron (502-3000) Series control is designed for field mounting. However, it should be mounted on the vessel so that vibration, corrosive atmospheres, and any possibility of mechanical damage are minimized. If this is not possible, the Drexelbrook LCS

series instrument with remote-mounted electronics should be substituted. The electronics may be mounted away from the sensing element at a distance specified by the cable length (normally up to 25 feet).

For convenience at start-up, it is best to locate the Z-tron Series control in a reasonably accessible location. It may be mounted either vertically or horizontally. See Figure 3-1.

The actual mounting location often depends on the placement of nozzles or openings into the vessel. Do not mount the instrument through a nozzle which exceeds the first insulator on the sensing element. See Figure 3-2. Be sure to protect the insulation on the sensing element against cuts and scrapes during installation.

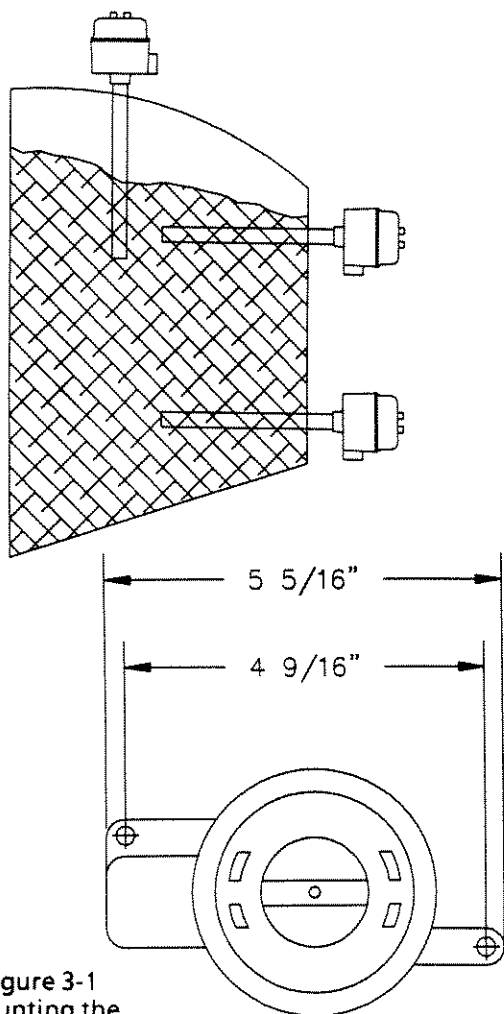

Figure 3-1  
Mounting the  
Sensing Element

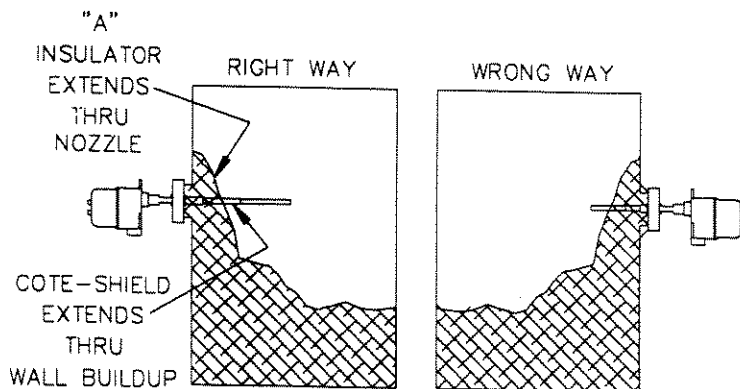

Figure 3-2  
Mounting Through a Nozzle

# Installation

## 3.3 Sensing Element Wiring

The sensing element connections to the integral electronics have been made at the factory. If it is necessary to rewire the sensing element to the electronics, see Figure 3-3 for proper connections. All of the sensing element connections are made to the land side of the circuit board. Be sure that the shield wire (orange) and the center wire (blue) are twisted.

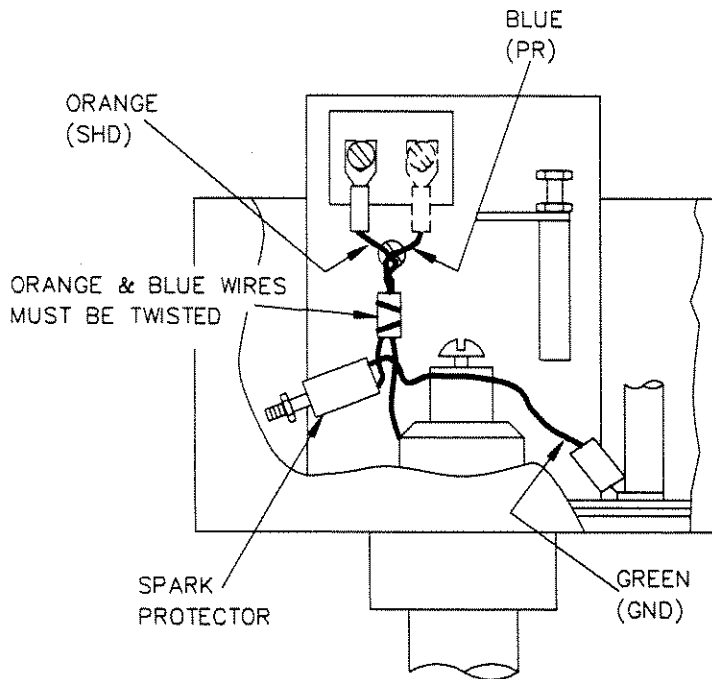

Figure 3-3  
Wiring of the  
Sensing Element  
to the Electronic Unit

## 3.4 Power Wiring

All power connections are made to the terminal strip on the top of the electronic chassis. See Figures 3-4, 3-5 and 3-6 for standard Z-tron, Z-tron B, Z-tron F and Z-tron D power connections, respectively.

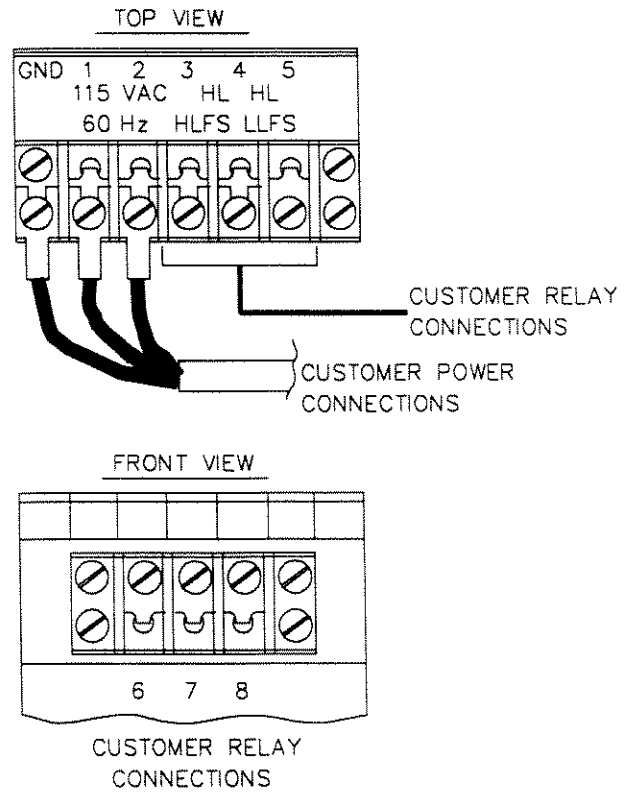

Figure 3-4  
Power and Relay Connections  
to the 120 Vac Unit  
Z-tron and Z-tron B

### 3.5 Relay Connections

The Z-tron relay has a double-pole double-throw (DPDT) contact closure. The relay serves as a switch and does not provide the power to operate an annunciator or other equipment. All relay connections are made to the terminal strip on the top of the electronic chassis. Refer to Figures 3-4, 3-5, or 3-6. For contact closures in high- and low-level failsafe, refer to Figure 3-7.

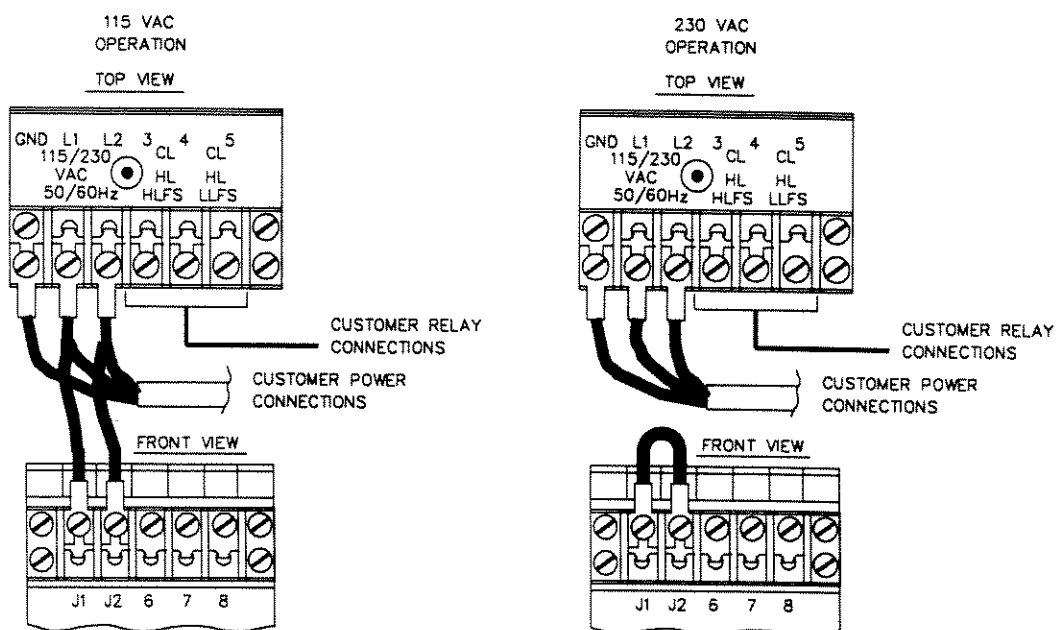
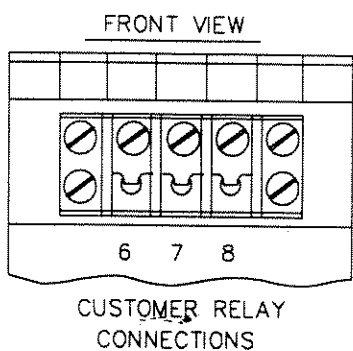
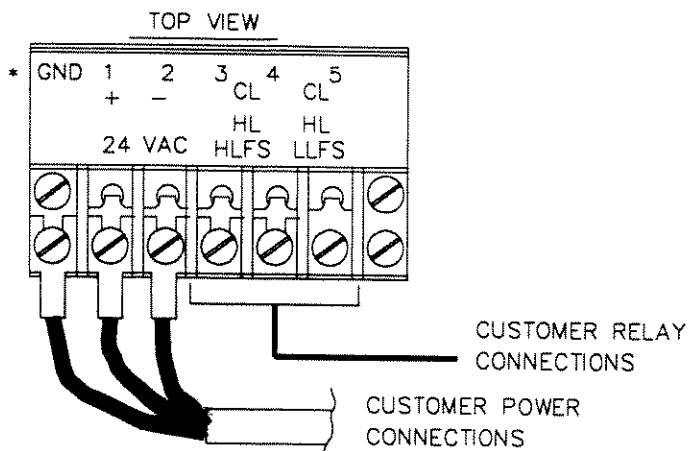

Figure 3-5  
Power and Relay Connections  
Z-tron F Units



\* POWER LINE NEED NOT BE GROUNDED TO INSTRUMENT.

Figure 3-6  
Power and Relay Connections  
Z-tron D Units

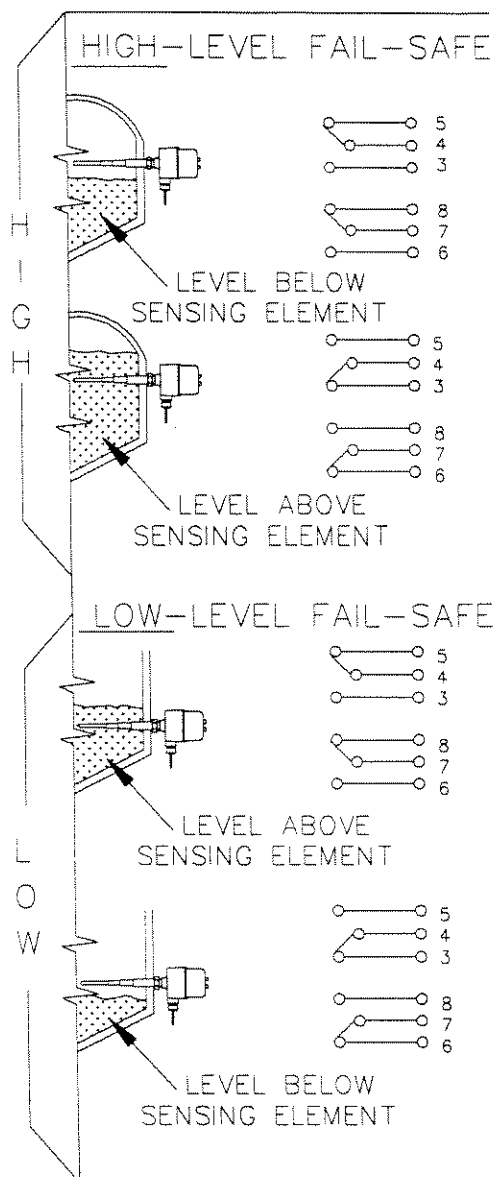

Figure 3-7  
Relay Contact Chart

## 4.0 Operation/Calibration

This section contains the operation and calibration procedures for the Z-tron Series point level controls.

### 4.1 Start-Up

Before applying power to the instrument, be sure that the power wiring is correct. See Section 3.4.

Warning: Units in hazardous areas.

Before the explosionproof housing cover is removed to calibrate the Z-tron control, the area must be checked and known to be non-hazardous. When calibration is complete, the cover must be replaced. Each connection to the explosionproof case must be equipped with an approved seal fitting.

### 4.2 Controls

#### 4.2.1 Operating Point Adjustment

There is a single operating adjustment used to control the level at which the relay operates. See Figure 4-1. Turning this adjustment clockwise (CW) will raise the level at which the relay operates, and turning the adjustment counterclockwise (CCW) will lower the level at which the relay operates. The LED (on) indicates the relay is energized.

#### 4.2.2 Fail-Safe Selector

Fail-safe describes the level condition which causes the output relay to de-energize.

High-Level Fail-Safe (HLFS) means the relay will de-ener-

gize under high level conditions, or upon loss of power. Low-Level Fail-Safe (LLFS) means the relay will de-energize under low level conditions, or upon loss of power. The instrument is supplied in the fail-safe requested when the order is placed. (HLFS, if not specified).

The fail-safe may be changed in the field by moving the position of the fail-safe connection located on the instrument circuit board. See Figure 4-2.

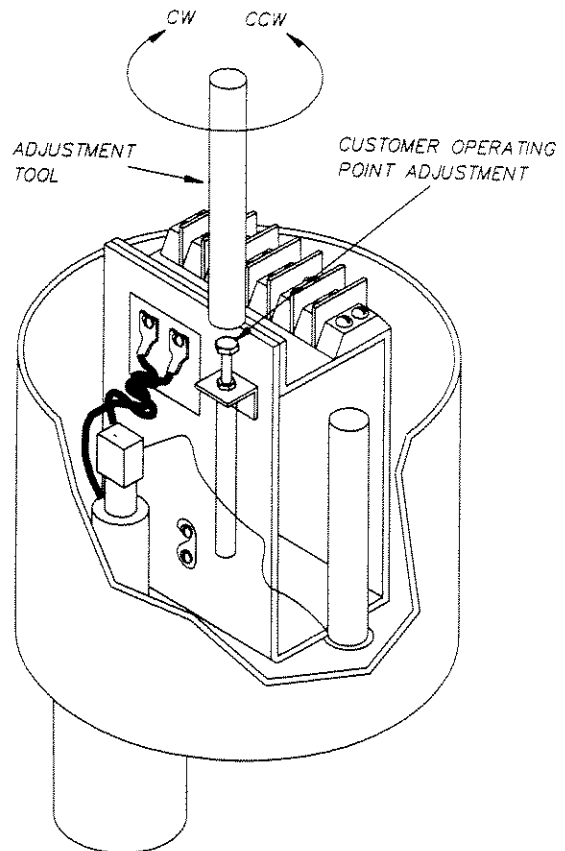

Figure 4-1  
Operating Point Adjustment  
with  
Calibration Adjustment Tool

## Operation/Calibration

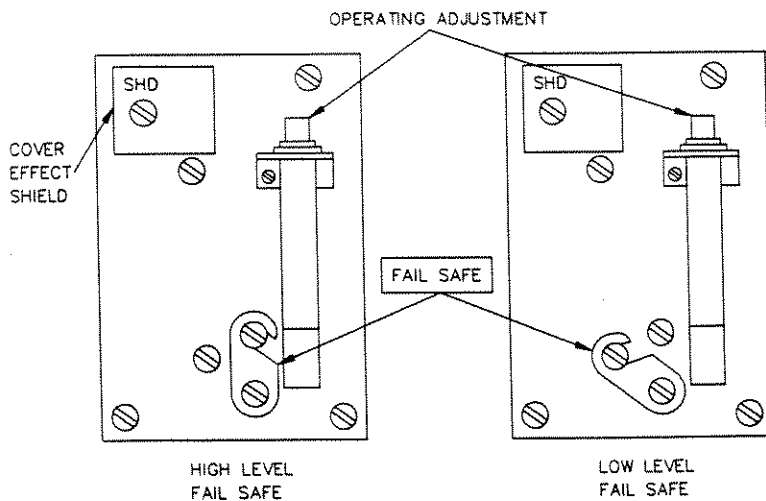

Figure 4-2  
Fail-Safe Selector

### 4.3 Calibration Procedures

Z-tron controls are factory set to switch in all water-based conducting materials. No calibration adjustment is necessary.

If the calibration adjustment has been tampered with, see Section 4.4 for recalibration of the unit in conducting materials.

If the material being measured is insulating, use one of the following calibration procedures.

#### 4.3.1 Calibration of Horizontal Controls in Insulating Materials

**Note:** Be sure to use the insulated calibration tool. See Figure 4-1. Do not turn any adjustment past its mechanical stops; damage to the unit may occur. LED on indicates that the relay is energized or in normal condition (not alarm).

- A. Be sure the material level is well below the end of the sensing element. See Figure 4-3.

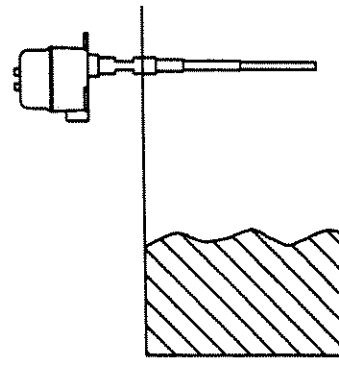

Figure 4-3  
Level Below the Sensing Element

- B. Using the insulated tool supplied with the instrument, turn the operating point adjustment to the full counterclockwise (CCW) position. See Figure 4-1.
- C. Turn the adjustment slowly clockwise (CW) until the relay just operates. (LED changes states).

- D. Increase the material level until it is well above the sensing element. See Figure 4-4. (LED changes states.)

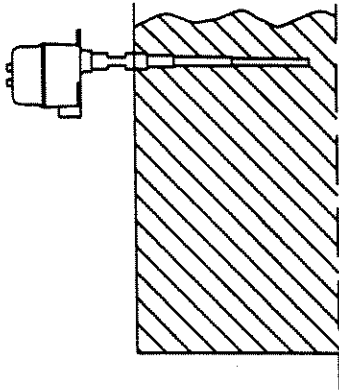

Figure 4-4  
Level Above the  
Sensing Element

- E. Mentally note the position of the adjustment tool pointer.
- F. Counting the number of turns, turn the adjustment slowly clockwise (CW) until the relay once again just operates, or you come to the end of the adjustment travel.
- G. Turn the adjustment back counterclockwise (CCW) one half the number of turns that were counted.
- H. For recalibration, record that half number of turns counted as "preload". See Section 4.6

Calibration is now complete.

**Note:** If only one-half or one full turn of the adjustment was required, set the pointer halfway between the point where the unit operated with the probe uncovered, and the point where the unit operated with the probe covered with material. If less than one-half turn of the adjustment was observed

between the sensing element covered and uncovered, please consult the factory.

#### 4.3.2 Calibration of Vertical Controls in Insulating Materials (or Vertical Insulated Controls in Conducting Materials)

**Note:** Be sure to use the insulated calibration tool. See Figure 4-1. Do not turn any adjustment past its mechanical stops; damage to the unit may occur. LED on indicates that the relay is energized or in normal condition (not alarm).

- A. Set the level to a point on the active section of the sensing element where control is desired (3 to 6 inches of coverage minimum). See Figure 4-5.

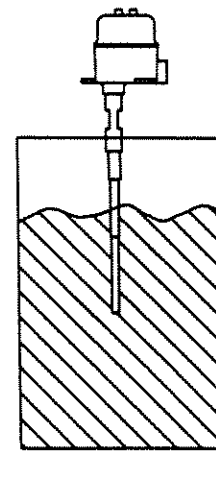

Figure 4-5  
Vertical Mount  
in Insulating Materials

- B. With the insulated tool supplied, start from the full counterclockwise (CCW) position and, counting the number of turns, turn the operating adjustment clockwise (CW) until the relay just operates. (LED changes states.) See Figure 4-1.



## Operation/Calibration

- C. Record the number of clockwise turns for recalibration.

Calibration is now complete.

**Note:** If the dielectric constant or conductivity of the material changes, the point of operation may change.

### 4.4 Blind Method of Calibration

The blind method of calibration is recommended when it is not possible to follow the standard method of calibration. The insulated calibration tool is required.

#### 4.4.1 Low-Level Fail Safe

- A. With the sensing element covered, find the operating point in material.
- B. Turn the adjustment back one-half turn rotation.
- C. Calibration is complete.

#### 4.4.2 High-Level or Low-Level Fail Safe

- A. With the sensing element in air, find the operating point in air.
- B. Turn adjustment clockwise one-half turn.
- C. Calibration is complete.

### 4.5 Calibration of Time-Delay Units

Refer to Figure 4-6 for location of time delay adjustment.

- A. Turn time delay adjustment to maximum counter-clockwise position (i.e. minimum time delay).
- B. Proceed with normal calibration procedure as described in paragraph 4.3
- C. After the instrument is adjusted to the desired operating point, turn the time delay adjustment clockwise until the re-

quired delay is achieved. For example, half rotation of the time delay adjustment will provide a delay of approximately 45 seconds. If the instrument is High-Level Fail Safe, the time delay will be with decreasing level. If the instrument is Low-Level Fail Safe, the delay will be with increasing level.

- D. Calibration is complete.

### 4.6 Recalibration

If the amount of preloading was recorded at the time of initial calibration, the instrument can now be replaced without experimentally determining the proper amount of preload.

- A. For recalibration using the procedure in Section 4.3.1, follow steps A, B, and C, then turn the adjustment further clockwise (CW) the amount of preload.
- B. For recalibration using the procedure in Section 4.3.2, turn the adjustment clockwise (CW), from the full CCW position, the amount of the recorded preload.
- C. For recalibration in conducting materials (factory set), use the insulated tool to turn the adjustment to the full clockwise (CW) position. No other adjustment is necessary.

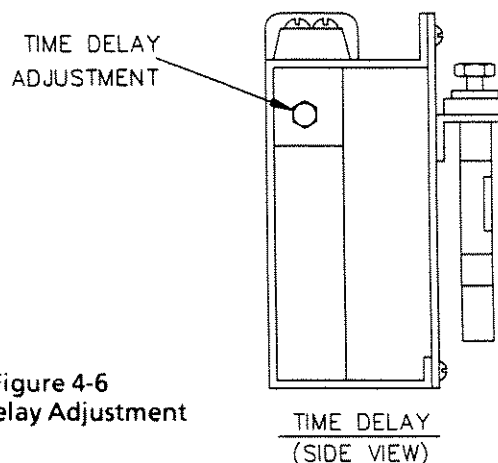

Figure 4-6  
Time Delay Adjustment

## 5.0 Troubleshooting

### 5.1 Introduction

The Z-tron (502-3000 Series) instruments are designed to give years of unattended service. No periodic or scheduled maintenance is required.

There are no specifically-recommended spare parts. However, if the application is critical, it is best to have a spare electronic chassis available in the event of a component failure. In most cases, a failed chassis should be returned to the factory for repair.

#### Backup Systems

"Drexelbrook equipment is built with great care and subjected to rigorous quality control. Even so, failures of any equipment can and do occur. Sound engineering practice demands that, whenever equipment failure may result in more than an inconvenience, a completely independent backup system be employed so that failure of either the unit or the backup unit will not permit a hazardous condition to occur."

If a difficulty should occur when operating your unit, test each part individually for proper operation.

The following troubleshooting procedures are recommended in checking out your level control. If attempts to locate the difficulty fail, notify your local factory representative, or call the factory direct and ask for the service department.

### 5.2 Testing the Electronics

A. See Figure 5-1. Disconnect the sensing element wires from the

instrument by removing the blue wire from the center terminal and the orange wire from the shield terminal. Leave the power connected.

- B. Connect a capacitor, any value from 10 to 50 pF, across the center and ground terminals. (Z-tron, Z-tron D and Z-tron F models only; excludes Z-tron B).
- C. Starting with the operating adjustment in the extreme counterclockwise (CCW) position, turn the calibration screwdriver clockwise (CW) until the relay just operates.
- D. Rotate the adjustment back and forth about this point, observing the travel of the pointer between relay pull-in and relay drop-out. If the instrument is working properly, the pointer on the tuning wrench should travel less than 1/8 turn to operate the relay.

If the instrument is not working properly, call the factory service department toll-free at 1-800-527-6297.

# Troubleshooting

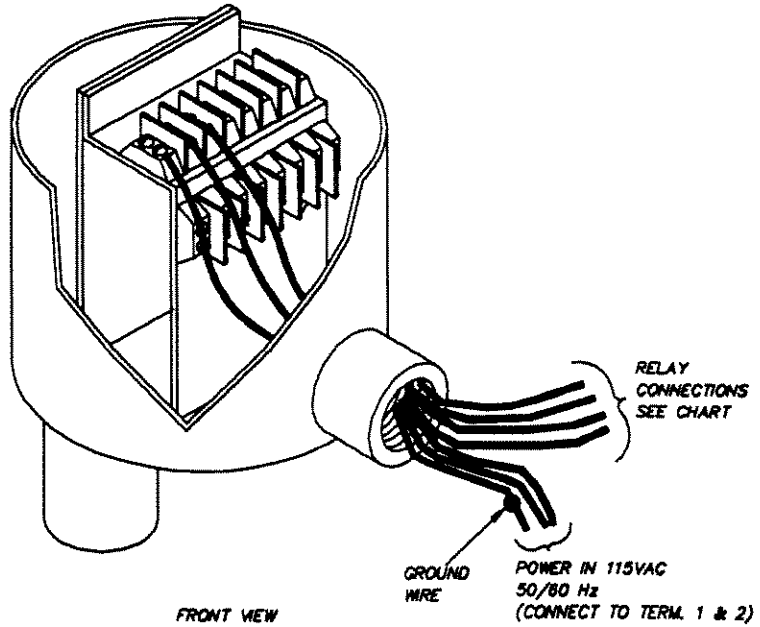
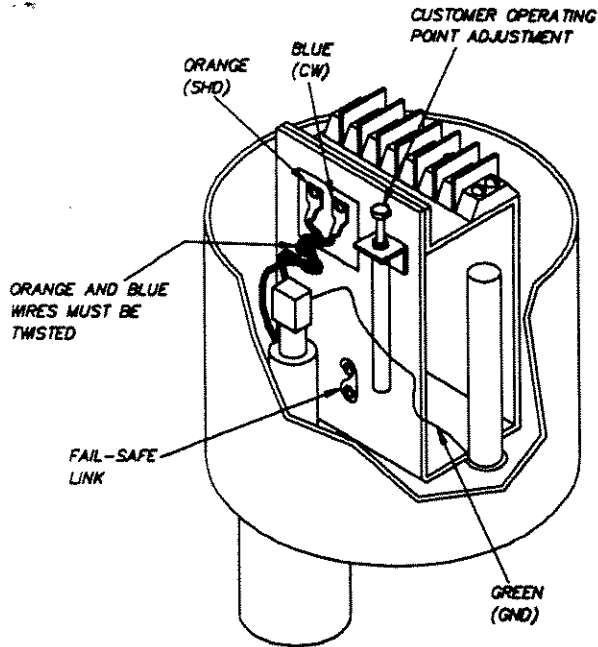

Figure 5-1  
Testing the  
Electronic Unit

**5.3 Testing the Sensing Element**

- A. See Figure 5-2. Disconnect the shield wire (orange) from the electronic unit and disconnect the spark protector from the center rod of the sensing element.
- B. With no material coating on the sensing element, use an analog ohmmeter to measure the following resistance values:

Resistance, center wire to shield \_\_\_\_\_

Resistance, shield to ground \_\_\_\_\_

Resistance, center wire to ground \_\_\_\_\_

- C. If all three readings are not above 1 megohm, consult the factory.
- D. If there is a material coating on the sensing element, use the analog ohmmeter to measure the following resistance values:

Resistance, center wire to shield \_\_\_\_\_

Resistance, shield to ground \_\_\_\_\_

- E. If either reading is less than 750 ohms, consult the factory.

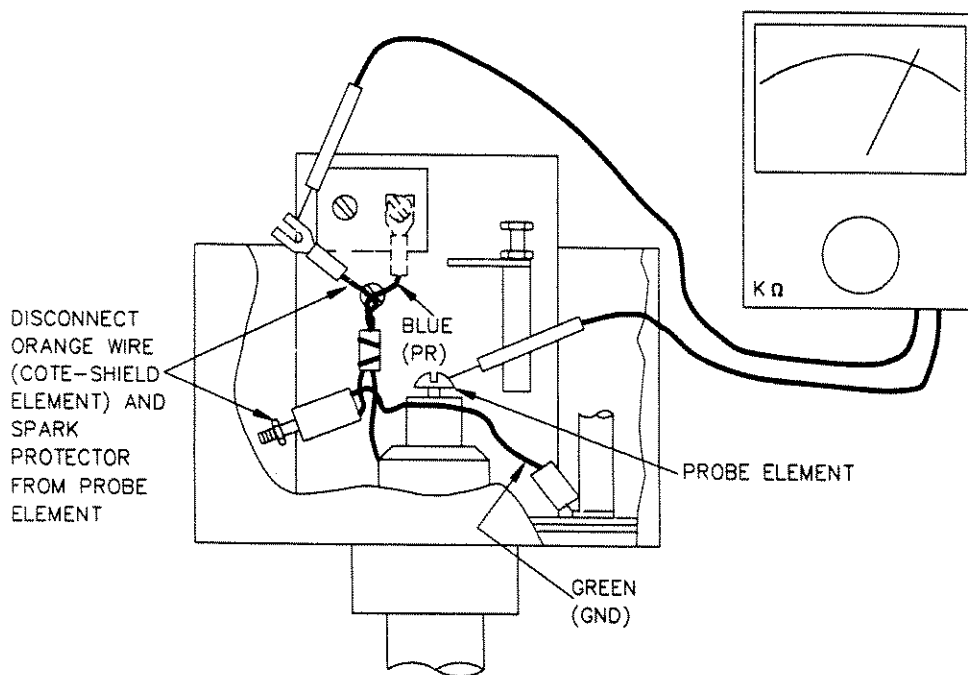

Figure 5-2  
Testing the Sensing Element

# Troubleshooting

## 5.4 Testing the Spark Protection

- A. See Figure 5-3. With the spark protector disconnected, use an analog ohmmeter to measure its resistive values.
- B. The resistance from the center wire tab to the blue wire should be between 44 and 50 ohms.
- C. The resistance from the center wire tab to the green wire should be equal to or greater than 1 megohm.
- D. The resistance from the blue wire to the green wire should be equal to or greater than 1 megohm.
- E. If any of the above readings are incorrect, consult the factory service department.

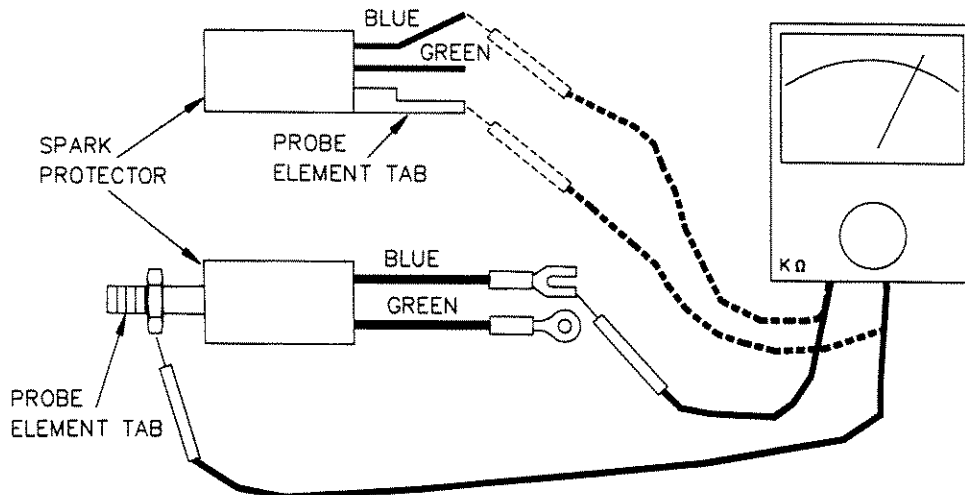

Figure 5-3  
Testing the Spark Protection

5.5 Testing the Relay Circuits

- A. The relay circuit consists of one set of double-pole, double-throw contacts brought out to a terminal strip. When the instrument is properly adjusted, two pairs of contacts will open with high or low level, and two pairs will close with high or low level.
- B. Adjust the instrument as described in Section 5.2
- C. Relay operation may generally be heard as an audible click when the background noise is not too high. Use one of the methods shown in Figure 5-4 to determine if the relay contacts are switching.
- D. Difficulty in calibration can often be traced to improper wiring of the relay terminals to an annunciator or other panel device. Check the wiring against the relay chart in Figure 3-7. Be sure to use the diagram for the fail-safe in which the instrument is functioning.

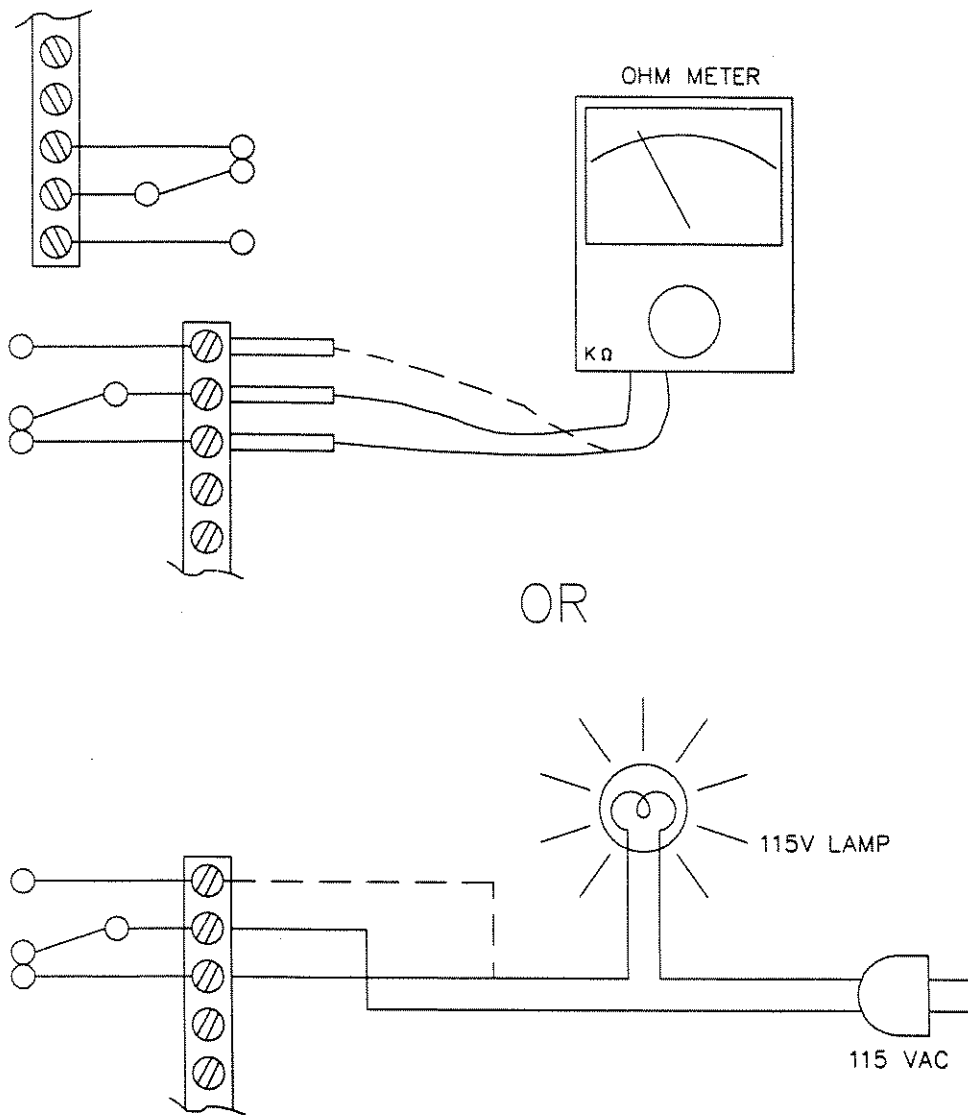

Figure 5-4  
Testing the Relay Circuits

5.6 Possible Problems and Causes

PROBLEM	POSSIBLE CAUSE	SOLUTION
1. Instrument indicates alarm at all times	<ul style="list-style-type: none"> <li>a. Coating build-up on sensing element (HLFS)</li> <li>b. Sensing element not "seeing" material (LLFS)</li> <li>c. Defect in sensing element</li> <li>d. Loss of power</li> <li>e. Improper wiring</li> <li>f. Improper calibration</li> <li>g. Electronic malfunction</li> </ul>	<ul style="list-style-type: none"> <li>a. Need longer Cote-Shield. Consult factory.</li> <li>b. Need longer insertion length. Consult factory.</li> <li>c. Sec. 5.3</li> <li>d. Sec. 3.4</li> <li>e. Sec. 3.3 &amp; 3.4</li> <li>f. Sec. 4.3</li> <li>g. Sec. 5.2</li> </ul>
2. Instrument never indicates alarm	<ul style="list-style-type: none"> <li>a. Coating build-up on sensing element (LLFS)</li> <li>b. Sensing element not "seeing" material (HLFS)</li> <li>c. Improper wiring</li> <li>d. Improper calibration</li> <li>e. Electronic malfunction</li> </ul>	<ul style="list-style-type: none"> <li>a. Need longer Cote Shield. Consult factory.</li> <li>b. Need longer insertion length. Consult factory.</li> <li>c. Sec. 3.3 &amp; 3.4</li> <li>d. Sec. 4.3</li> <li>e. Sec. 5.2</li> </ul>
3. Instrument can't be calibrated	<ul style="list-style-type: none"> <li>a. Improper wiring</li> <li>b. Insufficient signal from sensing element</li> <li>c. Setpoint is beyond the tuning range of the electronics</li> <li>d. Electronic malfunction</li> </ul>	<ul style="list-style-type: none"> <li>a. Sec. 3.3 &amp; 3.4</li> <li>b. Need longer insertion length. Consult factory.</li> <li>c. Consult factory.</li> <li>d. Sec. 5.2</li> </ul>
4. Instrument gives a false alarm	<ul style="list-style-type: none"> <li>a. Improper calibration</li> <li>b. Loose wiring</li> <li>c. Electronic malfunction</li> </ul>	<ul style="list-style-type: none"> <li>a. Sec. 4.3</li> <li>b. Sec. 3.3 &amp; 3.4</li> <li>c. Sec. 5.2</li> </ul>
5. Instrument operates intermittently	<ul style="list-style-type: none"> <li>a. Improper calibration</li> <li>b. Loose wiring</li> <li>c. Electronic malfunction</li> </ul>	<ul style="list-style-type: none"> <li>a. Sec. 4.3</li> <li>b. Sec. 3.3 &amp; 3.4</li> <li>c. Sec. 5.2</li> </ul>

## 6.0 Factory & Field Service

### 6.1 Telephone Assistance

If you are having difficulty with your Drexelbrook equipment, and attempts to locate the problem have failed, notify your local Drexelbrook representative, or call the factory direct and ask for the service department. Drexelbrook Engineering Company is located at 205 Keith Valley Road, Horsham, PA 19044. The telephone number is 1-800-527-6297. To help us solve your problem quickly, please have as much of the following information as possible when you call:

Instrument Model # See Section 1.2.1

Probe Model # not applicable

P.O. # \_\_\_\_\_

& Date \_\_\_\_\_

Cable Length \_\_\_\_\_

Application \_\_\_\_\_

Material being measured \_\_\_\_\_

Temperature \_\_\_\_\_

Pressure \_\_\_\_\_

Agitation \_\_\_\_\_

Brief description of the problem \_\_\_\_\_

\_\_\_\_\_

Checkout procedures that failed \_\_\_\_\_

\_\_\_\_\_

\_\_\_\_\_

### 6.2 Equipment Return

Do not return equipment without first contacting the factory for a return authorization number. Any equipment being returned must include the following information in addition to the above.

Reason for return \_\_\_\_\_

Return Authorization # \_\_\_\_\_

Person to contact at your company \_\_\_\_\_

"Ship To" address \_\_\_\_\_

\_\_\_\_\_

If available, please also include the original P.O. # and the original Drexelbrook #.

To keep the paperwork in order, you must include a purchase order with returned equipment, even though it may be coming back for warranty repair. You will not be charged if the equipment is covered under warranty. Please return your equipment with freight charges prepaid. We regret that we cannot accept collect shipments.

Drexelbrook usually has exchange units available for faster turnaround of repair orders. If you prefer your own unit repaired rather than exchanged, please mark clearly on the return unit, "Do Not Exchange".

Standard electronic units are generally in factory stock. If the application is critical, a spare chassis should be kept on hand.

### 6.3 Field Service

Trained field service personnel are available on a time-plus-expense basis to assist in start-ups, diagnosing difficult application problems, or in-plant training of personnel. Contact the service department for further details.



### **6.4 Customer Training**

Periodically, Drexelbrook instrument training seminars for customers are held at the factory. These sessions are guided by Drexelbrook engineers and specialists, and provide detailed information on all aspects of level measurement, including theory and practice of instrument operation. For more information about these valuable workshops, write to Drexelbrook Engineering, attn: Communications/Training Group, or call direct (215)674-1234.





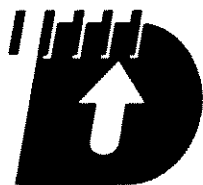

DREXELBROOK

---

Engineering Company